

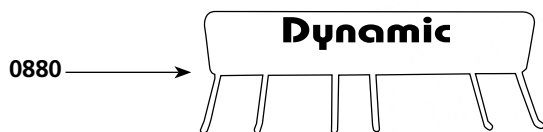

Parts list	Code
Carbon brushes (2)	0514
Ball bearing	0601
Squeezing washer	0726
Wall bracket	0880
Non-locking switch	0908
Capacitor	0909
Strain relief 230 V	0950
Strain relief 115V	0950.1
Warning label	1017
Dynamic label	1027
Label w/ serial number 230 V	1071
Label w/ serial number 115 V	1072
Variable speed control board 230 V	1213
Variable speed control board 115 V	1214
Brace screws (4)	7903
Braces (4)	7913.F
Variable speed control knob	8609
Power cord 230 V	9011
Stator screws (2)	9023
Self-lubricating ring	9025
Coupler for armature	9028
Power cord 115 V	9040
Handle screws (3)	9502
Switch protector	9813
Upper motor casing	9817
Fan	9818
Rotor w/ o coupling 230 V	9819
Rotor w/o coupling 115 V	9819.1
Stator 230 V w/ carter, carbon brushes holders	9820
Stator 115 V w/ carter, carbon brushes holders	9820.1
Upper half handle	9832
Complete handle 230 V	9840
Complete handle 115 V	9840.1
Lower half handle w/ label 230 V	9841
Lower half handle w/ label 115 V	9841.1
Aluminium carter + ball bearing	9842
BM 250 Motor block (see machine catalogue)	AC005

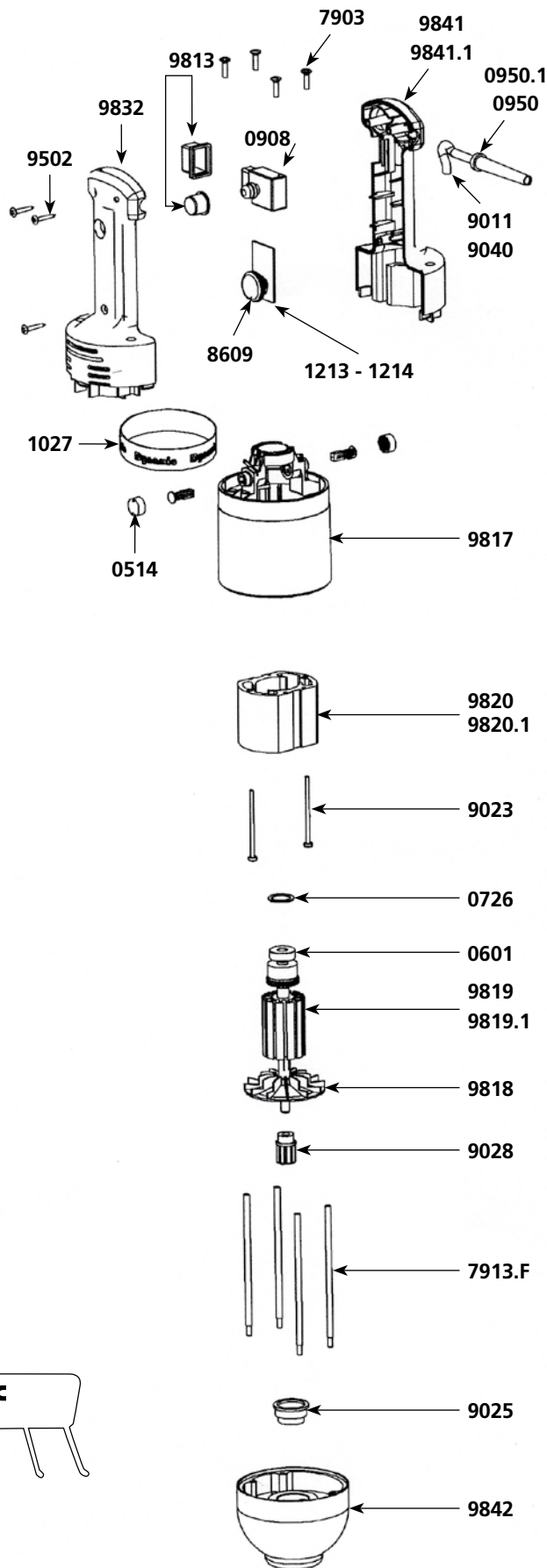

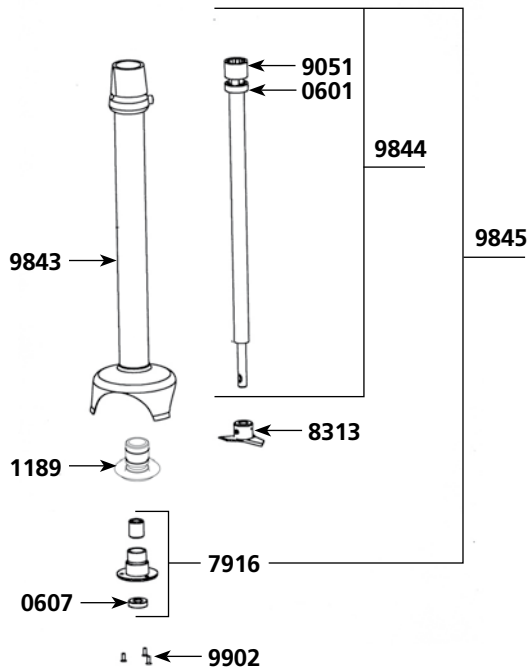

PMF 250 mixer tool

Parts list	Code
Ball bearing	0601
Waterproof seal	0607
Bearing holder + seal	1189
Lower ball bearing assembly (w/ o screws)	7916
Cutter blade (w/ screw)	8313
Coupling casing + pins	9051
Tube assembly + bearing	9843
Shaft & coupling sleeve	9844
Shaft, lower bearing & cutter assembly	9845
Lower bearing screws (3)	9902
M 250 Complete Mixer tool (see machine catalogue)	AC006

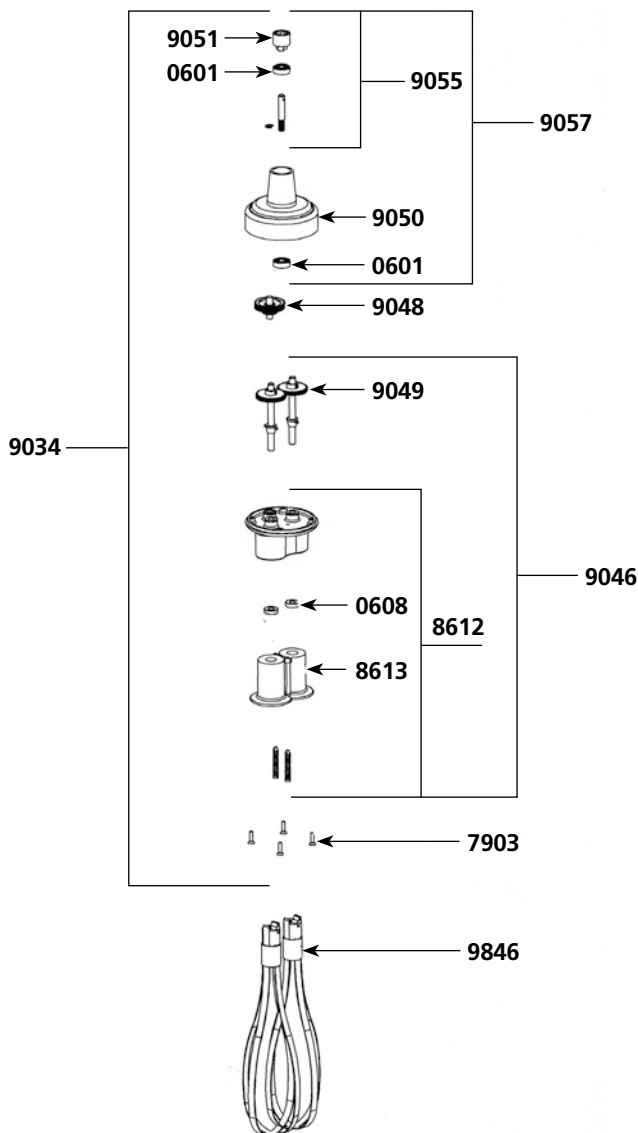

PMF 250 whisk tool

Parts list	Code
Ball bearing	0601
Waterproof seal for whisk	0608
Pin 3 X 20	0744
Pin 3 X 14	0745
Brace screws (4)	7903
Holder + plastic ejector + seal	8612
Plastic ejectors (pair)	8613
Reduction gear assembly	9034
Lower casing w/ o middle gear	9046
Central double gear & shaft	9048
Single gear (2) + pin	9049
Upper plastic casing	9050
Coupling casing + pin	9051
Equipped upper shaft	9055
Complete upper casing	9057
Whisks (2)	9846
F 250 Complete whisk tool (see machine catalogue)	AC007